

# Heated FID 3-800SE

## Portable THC/TVOC Analyzer

The Model 3-800SE is a lighter weight and portable, low priced compact and FULLY heated FID (HFID) based total hydrocarbon analyzer for high accuracy, sensitivity and stability at a lower price. The majority of other brands is not fully heated. The 3-800SE replaces our former OVF3000.

The 3-800SE is designed to be in full compliance with EN 14181, EN ISO 14659, EN ISO 12619 throughout the EU. EN 12619:2013 is optional. In the USA it fully complies with EPA Method 25A.



Low purchase price. Low cost of ownership. Low fuel gas consumption. No burner air cost; Combustion air supply for the FID detector built in. No external cylinder for synthetic air needed.

Optional available, safe to operate low pressure fuel gas metal hydride purifier/storage. (See left side in picture above). The stored and purified fuel gas in the metal hydride cartridge is always 5.0 quality or better, very sufficient to operate the FID analyzer for a good 30 to 35 hours continuously. Fuel gas refill from a master cylinder is safe and easy with any standard cylinder regulator with an output of 15 bar by using our convenient and safe fill/refill station. The optimal charging pressure is 10 bar (0,1 MPa).

## General:

Throughout the EU our new Model 3-800SE analyzer fully complies with EN 12619, EN 13526, EN 14181/ EN 12619:2013 and in the USA it fully complies with the EPA Method 25A and EPA Method 503.

The Model 3-800SE is our replacement for the OVF-3000 which was designed too fragile and had related light weight long term problems. The 3-800SE uses our over 49 years time proven Hydrogen Flame Ionization Detector (FID) which together with all other parts and sample transporting components are individually integrated in a 190°C heated oven to prevent heavy hydrocarbon hang up and is easy to be maintained and serviced. In comparison many other portable FID brands which are only partially heated FID analyzers. The 3-800SE though utilizes a consequently fully heated through high heat 190°C hot chamber which discretely and maintenance friendly houses all measuring and sampling components like sample filter, sample pump, sample pressure elements and the detector. Only this technique safely prevents the loss of high molecular weight hydrocarbon condensation to ensure true and long standing accurate measuring results, fast response, fast set back to zero and very reliable performance in the analysis of low to high ppm-levels of total hydrocarbon concentrations of contaminants in stack emissions, vehicle emissions, process gases, exhaust air and other gases. The standard disposable heated sample filter is easily accessible in the rear panel. No special tools are required for a quick, safe and easy sample filter change. When the user has opted for, the 3-800SE can be factory equipped with our high tech, low pressure solid metal hydride fuel purifying storage system which is safely kept in the left side of the analyzer. The holding mechanism already exists. The user can safely, legally and easily refill the purifying fuel cartridge himself at a very low pressures from any hydrogen cylinder at 8 to 10 bar (0.08 to 0.1MPa). The 3-800SE reflects low cost of ownership and has very low fuel gas consumption. The combustion air supply for the FID detector is already built in. Consequently no external burner air generator or external high pressure cylinder for synthetic burner air is needed. Safe 8 to 10 bar (0.08 to 0.1MPa) low pressure recharging from any master cylinder.



The optional available FSS 38 is an easily accessible, low pressure cartridge to store and always purify the fuel gas to a 5.0 quality. It allows up to 30 to 35 hours of uninterrupted continuous operation of the analyzer, it is clipped onto the optional cartridge holder in the left analyzer side panel

## Analyzer Features

- x Made in Germany
- x Very robust
- x Continuous long term measurement 24 hours/ 7 days week for week. Compare to rack mount analyzer
- x Digital RS232 data output
- x Analog voltage and mA signal outputs
- x Fast response within 0.2 seconds on sample inlet
- x Portable, convenient easy to carry dimensions
- x Optional low pressure FID fuel purifying storage system holds enough fuel gas for approx. 30 to 35 hours of continuous operation depends on the filling pressure of fuel cartridge
- x For safety reason maximum hydrogen filling pressure is 8 to 10 bar (0,8 to 1 MPa)
- x Cartridge for purifying and holding fuel gas as metal hydride is the guarantee for maximum safety and no explosion risk.
- x Designed for continuous operation
- x All components which come in contact with sample gas are made of stainless steel and are fully heated and temperature controlled at 190°C
- x Easy to change disposable sample filter in the rear panel. No special tools required for filter change
- x Long life FID ignition system
- x Built in burner air generator, no external combustion air source needed
- x Built-in sample pump and air pressure pump, no external sample pump needed
- x Automatic flame out alarm and fuel shut off with power off
- x 6 digit direct read ppm display, measure up to a maximum of 2 or 3 measuring ranges without range change
- x Low fuel consumption
- x Very selective to hydrocarbons
- x Excellent accessibility for easy maintenance and service

## Applications

- x Stack gas hydrocarbon emissions monitoring
- x Long term replacing a defective QAL1 specified rack mount FID analyzer in an AMS. The 3-800SE was intentionally designed for this application
- x RDE Testing: Measuring automotive raw exhaust total hydrocarbon emissions during driving conditions of the car
- x RDE Testing: Small enough to be used in the trunk or back compartment of a car in addition to the typical NO/NO<sub>x</sub>/CO/CO<sub>2</sub> monitoring systems which are mounted inside or outside of the car
- x Raw exhaust total hydrocarbon vehicle emissions analysis
- x Catalytic converter testing automotive and stack emissions testing
- x Fence line monitoring
- x Measuring engine combustion efficiency
- x Hydrocarbon contamination monitoring in air and other gases
- x Carbon adsorption regeneration monitoring and control
- x Indoor air quality monitoring
- x Detection of trace hydrocarbons in purity gases used in the semi conductor industry
- x LEL monitor of solvent laden air

## Principle of Operation

The Heated Flame Ionization Detector (HFID) method is used in this analyzer to determine the presence of total hydrocarbon concentrations in gaseous samples.

Burning hydrocarbon-free hydrogen in the presence of hydrocarbon-free air inside of the detector produces a negligible number of ions between two semi-cylindrical electrodes which produce a well-recognizable base signal. Once a sample which contains any gaseous organic carbon matter is introduced into this flame, a very complex ionization process is started. This process creates a large number of ions. A high polarizing voltage is applied between the two semi-cylindrical electrodes around the burner and produces an electrostatic field. In which negative carbon ions migrate to the collector electrode and positive hydrogen ions migrate to the high voltage electrode. The so-generated ionization current between the two electrodes is directly proportional to the hydrocarbon concentration in the sample that is oxidized by the flame. This signal is measured and amplified by a highly sensitive and stable electrometer amplifier unit. The FID response is linear over six orders of magnitude. The typical detection limit of the detector is 100 ppb. This signal is collected, A/D converted and amplified by our highly sensitive and rugged electrometer amplifier unit.

Our proprietary sample pressure regulator comes not in contact with sample gas. With its heated bypass capillary it provides a controlled sample back pressure which gives admittance of a highly constant sample flow rate into the FID burner. This technique of using our non-sample contacted pressure regulator is an in-house invention dated back to 1974 and is time-proven for over 49 years by J.U.M. Engineering to provide the highest stability of the sample pressure and highest sample flow rate stability at lowest maintenance. Our compactly designed FID flow control module for fuel, ignition and air flow rates via low thermal mass needle valves use high-precision pressure regulators. The needle valves are factory-adjusted and sealed to ensure long-time optimized detector conditions.

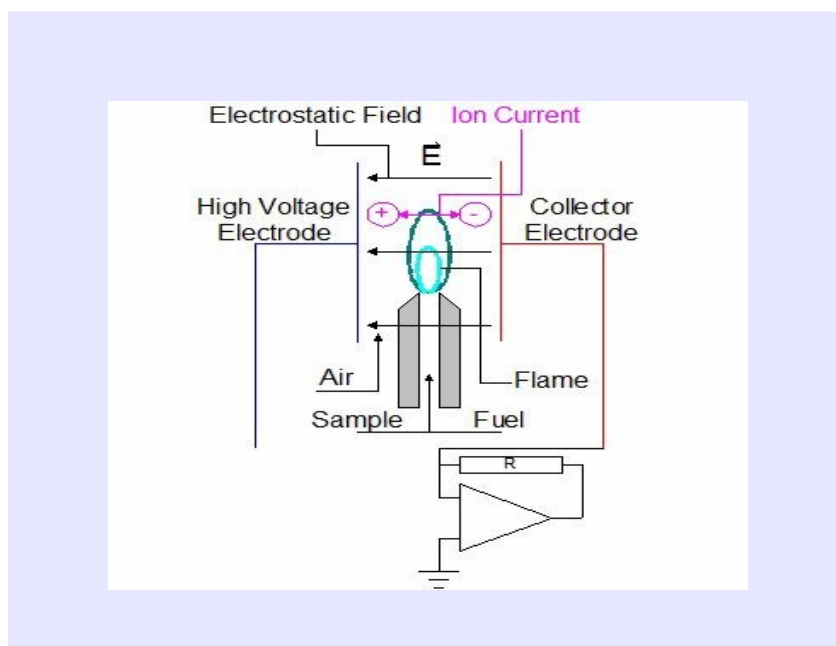

Portable 3-800SE heated FID Total Gaseous Organic Carbon Analyzer

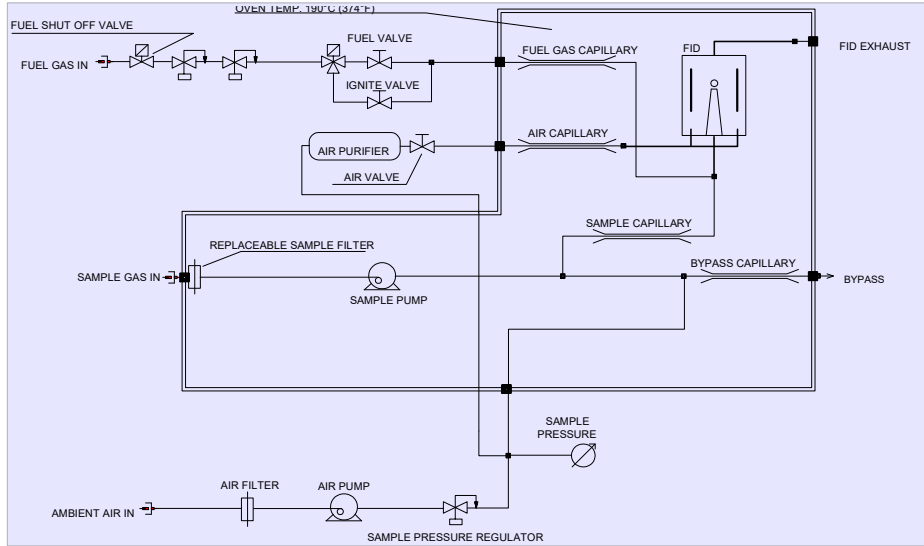

Complete flow diagram shown



Rear Panel



Optional Hydrogen Fuel Purifier and storage Cartridge (Metal Hydride)



Hydrogen Fuel Purifier Cartridge Shown with master cylinder and optional filling adapter



Optional Calibration Box is already set to 1 bar Cal. Gas Inlet Pressure

### Technical Specifications

Method	Heated Flame Ionization Detector (HFID)
Sensitivity	Max. 1 ppm CH <sub>4</sub> full scale (100 ppb)
Response time	@ sample inlet <0.2 seconds
t <sub>90</sub> time	@ sample inlet <1.2 seconds
t <sub>90</sub> time through sample line	Including 185 °C heated sample line (7.5m) and sample filter probe: less than 8 seconds
Zero drift	<2% full scale / 24h
Span drift	<2% full scale / 24h
Linearity	Up to 10.000 ppm full scale reading within <2.5% FSD
Oxygen synergism	<2.5% FSD
Measuring ranges (ppm)	Front panel turn switch: 0-10, 100, 1.000, 10.000, 100.000, others on request.
Automatic Flame out alarm	Equipped with automatic fuel shutoff valve
Signal outputs	0-10 VDC, 4-20 mA and standard RS-232 data output
Display	6- digit direct reading ppm units capability to measure two (2), max. three (3) overlapping measuring ranges without range change
Total sample flow through	2.5 to 2.8 l/min capacity @ operating temp.
Heated sample filter	Disposable 2 micron change filter in rear panel
Zero and Span gas	Via sample inlet by using an overflow "T" fitting or by using optional calibration box ECB 38
Zero and span adjust	Manual via duo dials on front panel
Fuel gas	100% H <sub>2</sub> , consumption approx. <20 ml/min, alternatively 60% He/40% H <sub>2</sub> approx. <80 ml/min. Must be selected with the ordering process.
Burner air consumption	Built in burner air supply. No external cylinder air needed. Flow approximately 130 ml/min
Oven temperature	190 °C (374 °F)
Temperature control	Micro-processor PID controller
Power requirements	230VAC/50Hz, 850W (120 VAC/60Hz optional)
Ambient temperature	5-43 °C (41-110 °F)
Dimensions (W x D x H)	300 mm x 580 mm x 204 mm
Weight	approx. 16 kg

### Available Options

FSS 38	Low pressure, 50 liter metal hydride hydrogen fuel Storage cartridge including mounted pressure regulator and pressure gauge on female 1/4" Swagelok quick connector. Refill from large cylinder is safe and can be made with standard 0 to 30 bar gas cylinder regulator. See inserted picture on 1st page of our data sheet UFS 32 Hydrogen Recharging Set; Pressure regulator for high pressure hydrogen cylinder equipped with Swagelok® flow through quick connector. <u>Includes the cartridge holder in the left analyzer side panel</u>
RC14 38	4-20 mA analog output, galvanic isolated
ECB 38	Calibration adapter box to be mounted on heated line inlet or analyzer sample inlet. Correct Flow already adjusted

## Questions and Answers about the low pressure rechargeable Hydrogen gas purifier/storage system

**Q: Is the new fuel gas filter storage high pressure cylinder?**

A: The FSS cartridge is not a high pressure cylinder. The metal hydride storage function is simply explained: hydrogen can be stored in this tank due to the chemical reaction between metal powder and gas. The hydrogen is chemically bonded, or absorbed by the metal without the need for higher compression rates. The new hydrogen FID Fuel Gas filter which stores Hydrogen as Metal Hydride. It is charged at a low pressure of 1 MPa (10 bar) and operates at pressures below 0.08 MPa (8 bar). It purifies contaminated Hydrogen to a very high 5.0 gas purity (99.999%). The gas filter is very safe and withstands pressures of over 200 bar.

**Q: Is the used filter storage a pressurized gas tank?**

A: No, it is not a pressurized gas tank. In this system hydrogen is purified and stored in form of solid metal powder which chemically reacts to metal hydride when it is contacted with hydrogen gas.

**Q: How could I know when I used up the purified hydrogen, and need to recharge?**

A: The FSS 38 uses a pressure regulator pressure to adjust and indicate the outlet pressure with its miniature pressure gauge. If the system is used correctly without a leak and the pressure in the storage drops below 0.15 MPa (1.5 bar) after approx. 20 to 30 hours the FID flame(s) slowly will go out. If no optional FDR 9 pressure regulator with pressure gauge is used, an elapse of approximately 20 to 30 hours after correct charging is a good enough indicator to recharge the system. Any kind of a pressure gauge in the fuel line can be used as an indicator.

**Q: Can your new gas filter system store gases other than Hydrogen?**

A: No, it is strictly designed to store and purify Hydrogen gas.

**Q: What will happen if system is charged with other gases than Hydrogen?**

A: In practice it will then work just like a pressurized tank. However, if the stored gas is another one than Hydrogen it may destroy the dense filling of metal alloy powder and the storage will no longer purify and hold hydrogen gas properly.

**Q: Is a pressure regulator required while using your new hydrogen storage system?**

A: Even though that the internal regulator of the analyzer can handle the raw cartridge pressure, we strongly suggest that the offered FDR 9 pressure regulator for the cartridge is always being used.

**Q: How long does it take to charge/recharge an empty cartridge?**

A: Recharging is simple and fast. Shortest case charge time is around 60 plus minutes to charge at a pressure of 10 to 12 bar (1 to 1.2 MPa) at ambient air temperatures. Best charging results are reached after a couple of hours after the cartridge has reached room temperature. Any standard hydrogen pressure regulator with an adjustable output range of 0 to 15 bar (0-15 MPa) or some higher can be used for charging.

Go quite much highly broken supply

**Q: What is the typical life span of the hydrogen purifying ?**

A: As purer the charged hydrogen gas is as higher is the life span of the system. When it is always charged with a high quality purity hydrogen like 5.0 or higher, the charge/discharge quantities can easily come to 9'000 plus cycles which count to less than 10% decay in storage capacity. In fact, it can be considered as a limitless refillable device.

**J.U.M.® Engineering GmbH**

Gauss-Str. 5, D-85757 Karlsfeld, Germany

Tel.: 49-(0)8131-50416

E-mail: [info@jum.com](mailto:info@jum.com)

Internet: [www.jum.com](http://www.jum.com)

© J.U.M. Engineering 2001/2024. Latest print release: March 20224